

Fire Pump Systems in NFPA 20 Standard

✓ ETN YN Series

The National Fire Protection Association (NFPA) was established in 1896 in the USA. NFPA 20 is referred to as the "Standard for the Installation of Stationary Pumps for Fire Protection" belonging to this organization and was first released in 1899. This standard identifies the features, performance and assembly rules of fire pumps, control panels and required auxiliary elements. NFPA 20 was revised multiple times since its initial release, with its most up-to-date version being the 2025 release.

ETNA (Alp Pompa Inc.) manufactures fire pumps in line with both EN 12845, a European Union standard, and NFPA 20 in order to fulfill national and international demands with its production experience of more than 35 years and expert sales team. ETNA, has been a member of NFPA since 2013.

General Properties of ETNA Fire Pump Systems in accordance with NFPA 20

Throughout the life cycles of the fire pumps, the maximum reliability is always the first priority. Thus, contrary to other pumps, savings and efficiency are not the main consideration.

What should the Performance Properties of a Fire Pump in line with NFPA 20 be?

Shut-off Pressure Value: The shut-off pressure value of the fire pump (maximum pump pressure at zero flow rate) should not exceed 140% of the nominal value.

Nominal Values: The intersection point of the requested flow rate and the pressure value on the pump hydraulic curve.

Maximum load: The fire pump curve should provide 150% capacity value of the nominal flow rate, and the pressure value at 150% flow rate capacity should not be less than 65% of the nominal pressure. "Curve 1" shows the curve limit values.

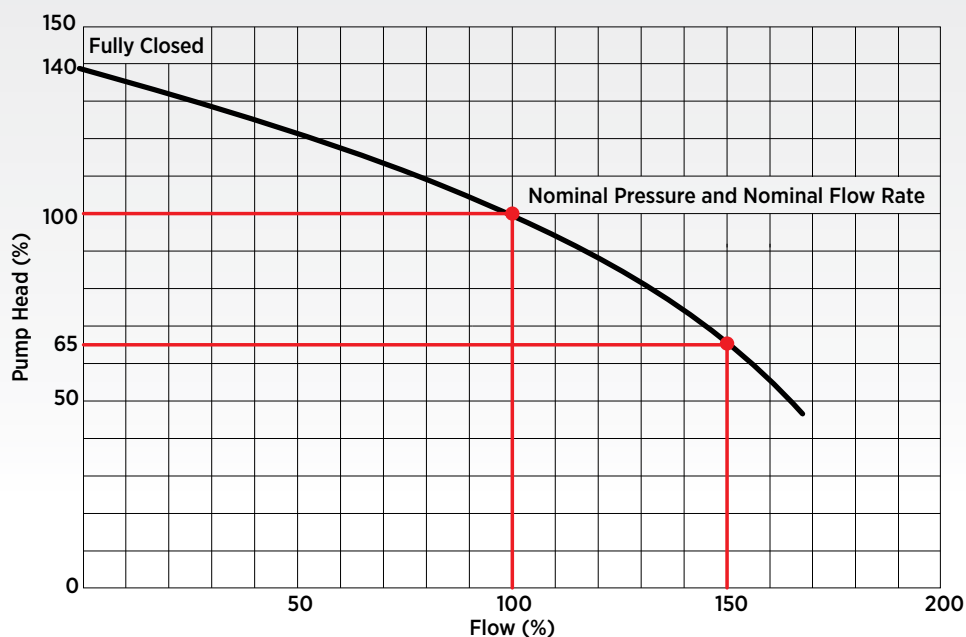

Curve 1: Characteristic Limit Value Curve

Note: The pump's closed valve pressure cannot be more than 1.4 times the nominal pressure. The pump pressure at 150% flow rate cannot be smaller than 65% of the nominal pressure.

- According to NFPA 20, the nominal flow rates of fire pumps are in the range of 25-5000gpm.
- Nominal pressure value is required to be 40psi or higher.
- Standard pump types are identified as end suction, vertical inline, horizontal split case and vertical turbine.
- Each pump should have an individual control panel. In NFPA 20, fire pump suction diameters are identified based on the maximum velocity at 150% of nominal flow rate (4.6m/sec).
- Outside screw and yoke (OS&Y) gate valve shall be installed in the suction pipe.
- Strainers are not permitted except for vertical turbine pumps.
- NFPA 20 allows suction from negative level only for "Vertical Turbine" pumps among fire pumps, and forbids negative suction by end suction and split case pumps.
- There should be a check valve and isolation valve in the discharge line of the fire pumps, in that order.
- If the fire pumps are electrically driven, the power supply shall be reliable and continuously available; otherwise, at least one of the fire pumps shall be driven by a diesel engine.
- Jokey pump is used to solve the issue of small pressure drops in the fire installation before the main fire pumps are activated; its flow rate must be min. 1/100 of the flow rate of the main fire pump and its pressure must be min. 1 bar above the pressure of the main fire pump.

Material Specifications

- Pump Impeller : GG25 Cast Iron or Bronze (CuSn7)
- Pump Shaft : AISI 420 Stainless Steel
- Casing : GG25 or GGG40 Cast Iron
- Sealing : Gland Packing or Mechanical Seal
- Coupling : Flexible Coupling
- Bushing : Grease Lubrication

Pump Equipments

- Air Release Valve (for both electrical and diesel pumps)
- Casing Relief Valve (for electric driven and radiator cooled diesel driven pumps)
- Manometer on delivery line and vacuum meter on suction line
- Required to be +4°C above the pump room against the risk of freezing.

Note: The suction and delivery lines of the fire pumps should be fixed to a stable surface with seismic protectors for protection against possible earthquakes and vibrations.



Description	
Pump set with diesel engine, electrical motor, and pilot pump	
Fire pump set with diesel engine and jokey pump	
Pump set with electrical motor pump and pilot pump	
Pump set with two electrical motor pumps and one pilot pump	

Table 1: NFPA 20 Fire Pump Versions

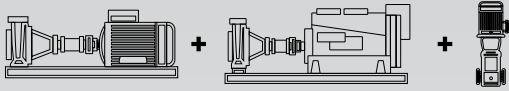
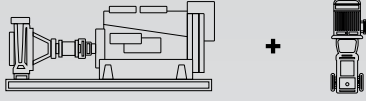
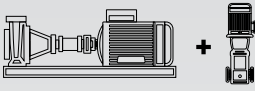
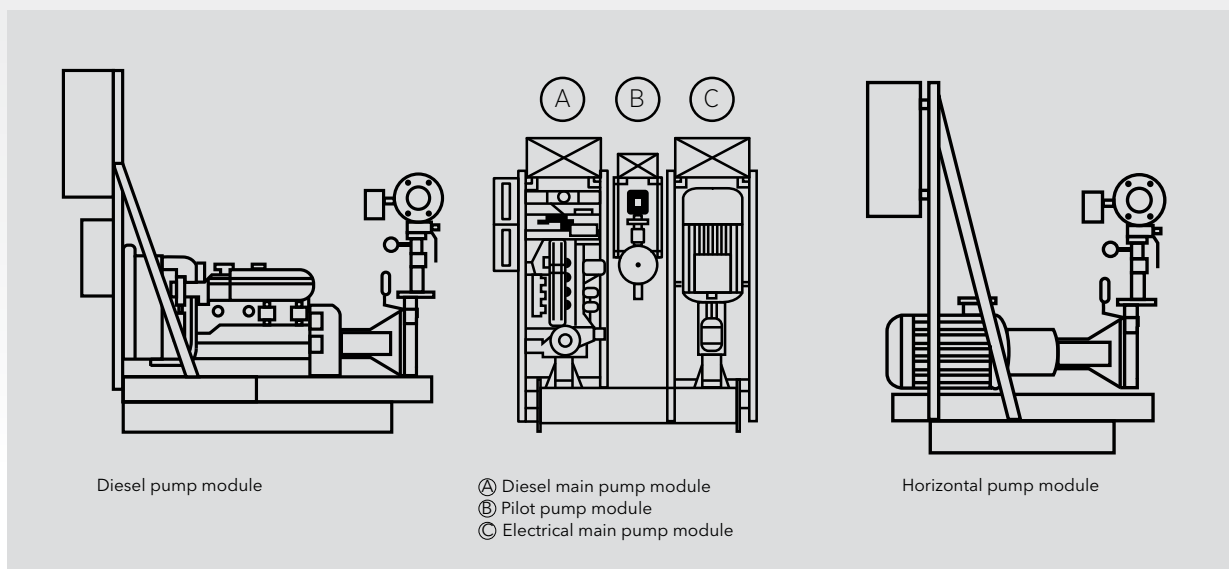

Figure 1: Modular System

- On the suction side of the fire pump, a continuous and straight suction pipe with a minimum length of 10 times the nominal pipe diameter shall be provided upstream of the pump suction flange.
- Elbows and tee fittings located within 10 pipe diameters of the pump inlet in the horizontal line can cause unbalanced flow. "Figure 2" illustrates correct and incorrect suction piping arrangements.

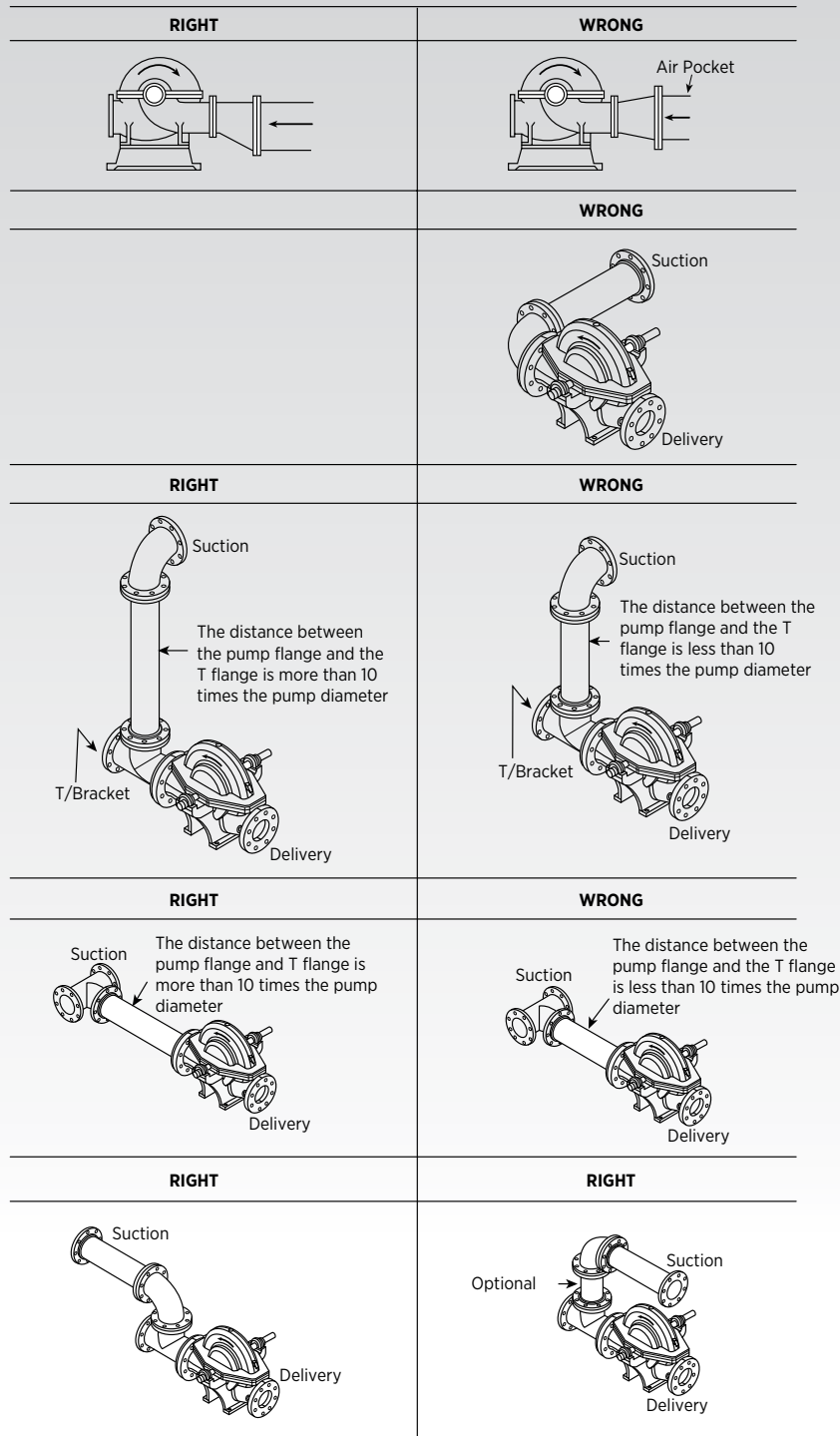

Figure 2: Pump Suction Line Connection Examples

- If the fire pumps draw water from a tank, a vortex plate shall be installed. The dimensions of the vortex plate should be as follows. The dimensions of the vortex plate are given in Figure 3.
- If required, an eccentric reducer must be placed at the inlet of the pump on the suction line, and a concentric reducer must be placed at the delivery line. The top of the eccentric reducer should be flat. The use of reducer on suction and delivery lines should be determined based on Table 1 in line with the pump flow rate.
- For example: if the suction diameter of a 750gpm pump is 6", there is no need to use a reducer. But if it is 4", it is required to use an eccentric reducer from 4" to 6".

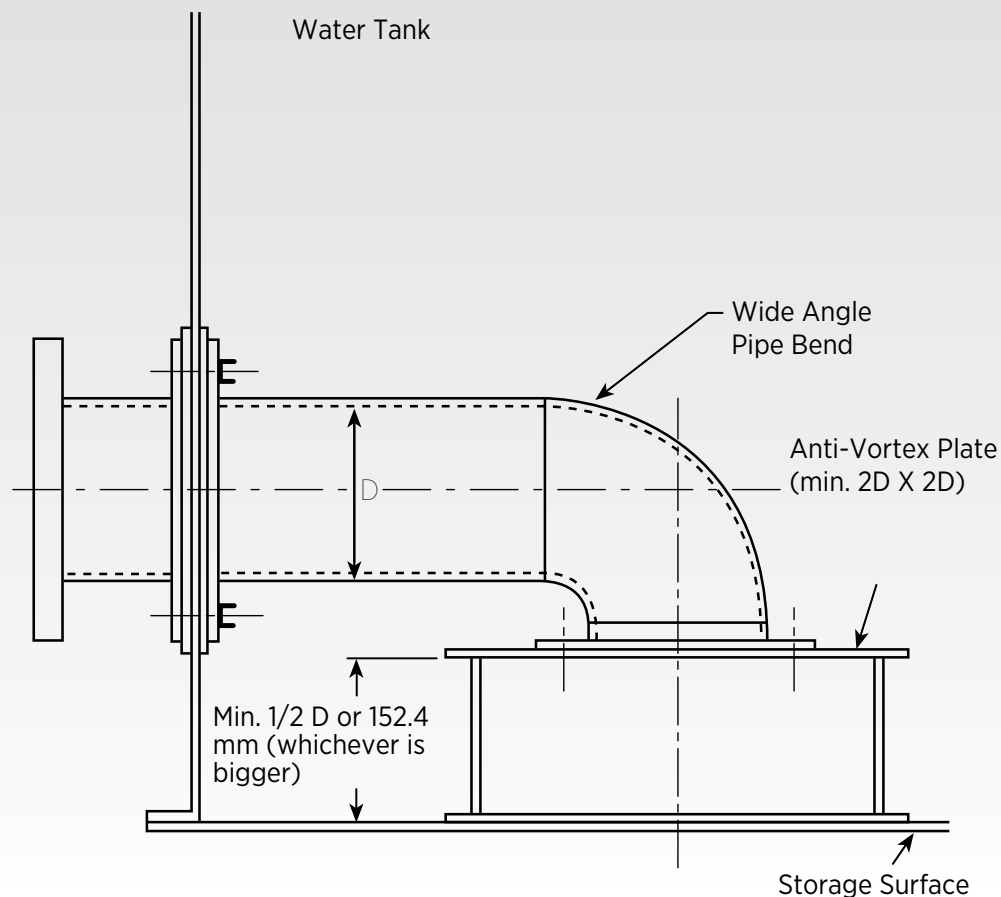

Figure 3: Vortex Plate Dimensions

- Flow meter diameter should be selected based on "Table 1" in line with the pump flow rate. Moreover, unlike in EN12845 which specifies a connection to the delivery collector, the NFPA 20 standard requires the flow meter to be connected between the butterfly valve and check valve on the pump delivery line, as shown on Figure 4.

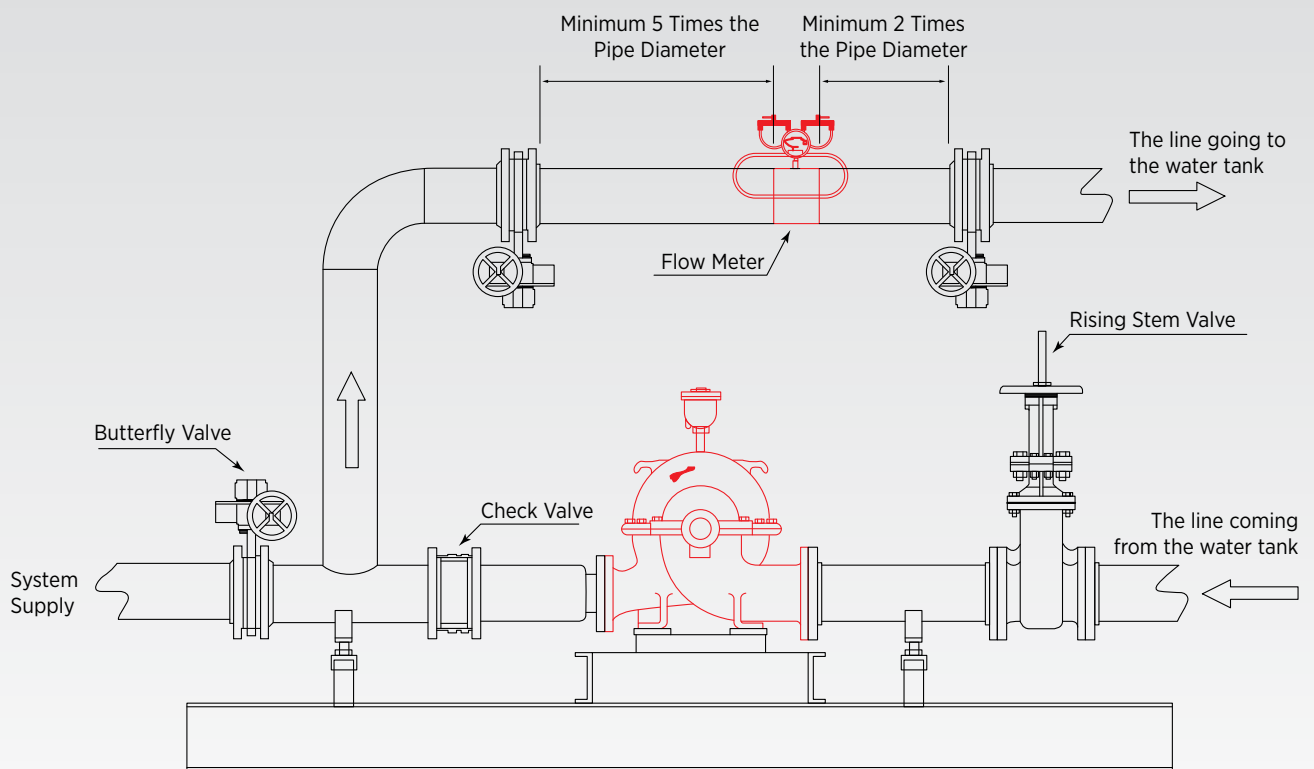
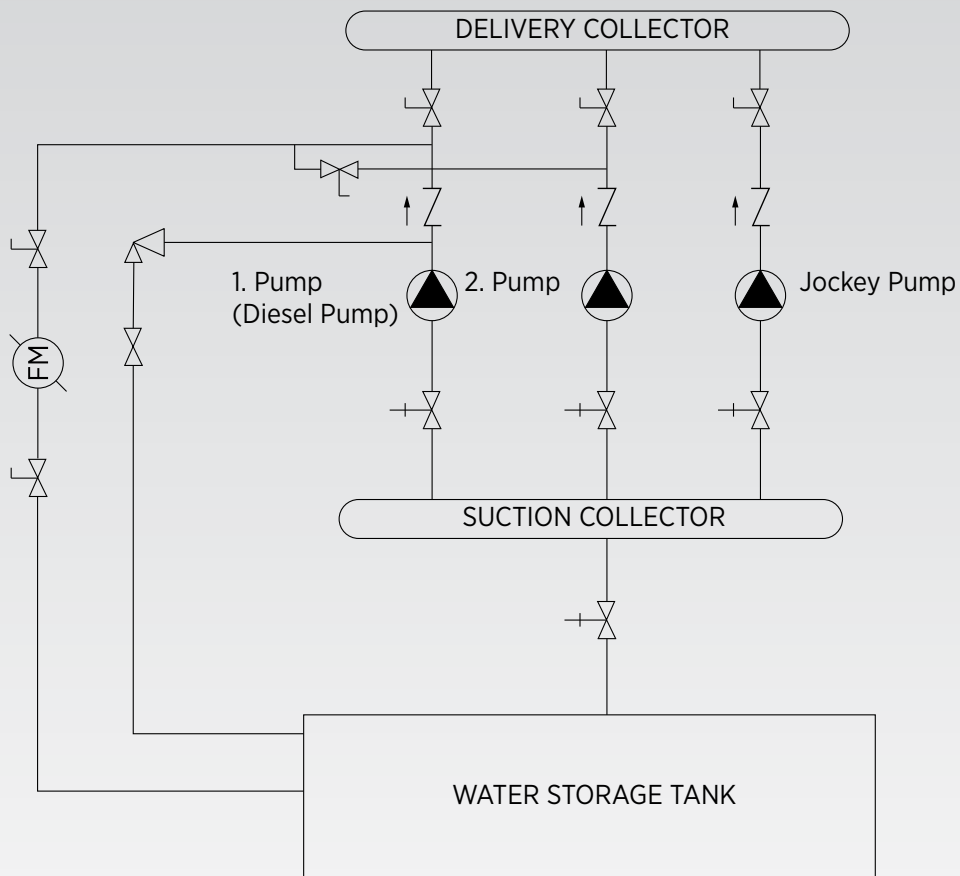

Figure 4: Flow Meter Connection Diagram

Fire Pump Flow Diagram in NFPA 20



- | | | | |
|--|--|--|--|
| | Butterfly Valve with Monitoring Switch | | Check Valve |
| | Flow Meter | | Pump |
| | Waste Cone | | Rising Stem Valve with Monitoring Switch |
| | Relief Valve | | |

Figure 5: Fire Pump Flow Diagram in NFPA 20

Fire Pump System Codes in NFPA 20

ETN YN / 100 / 270 / 1 / 90 / D96 / 10-9

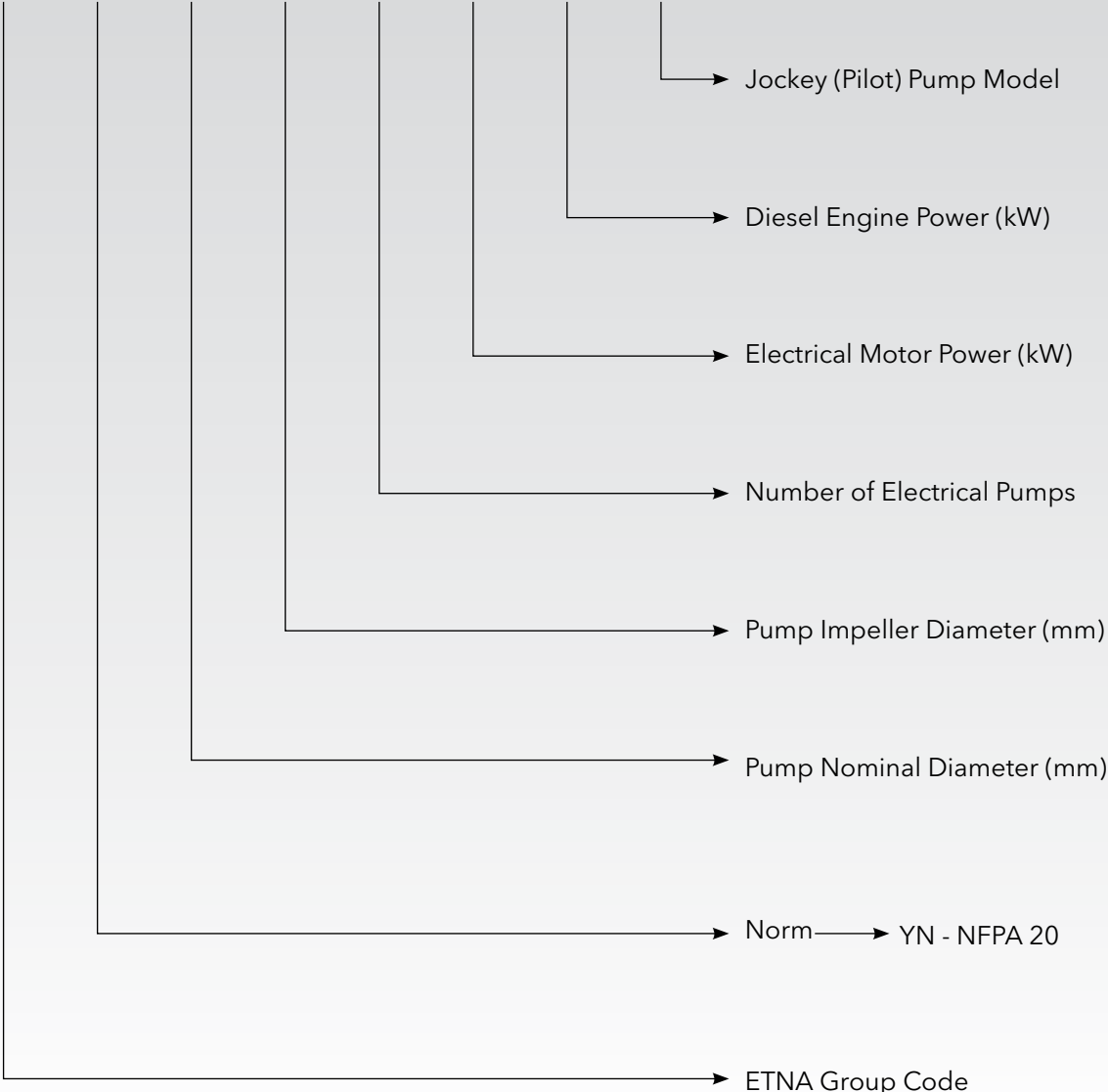

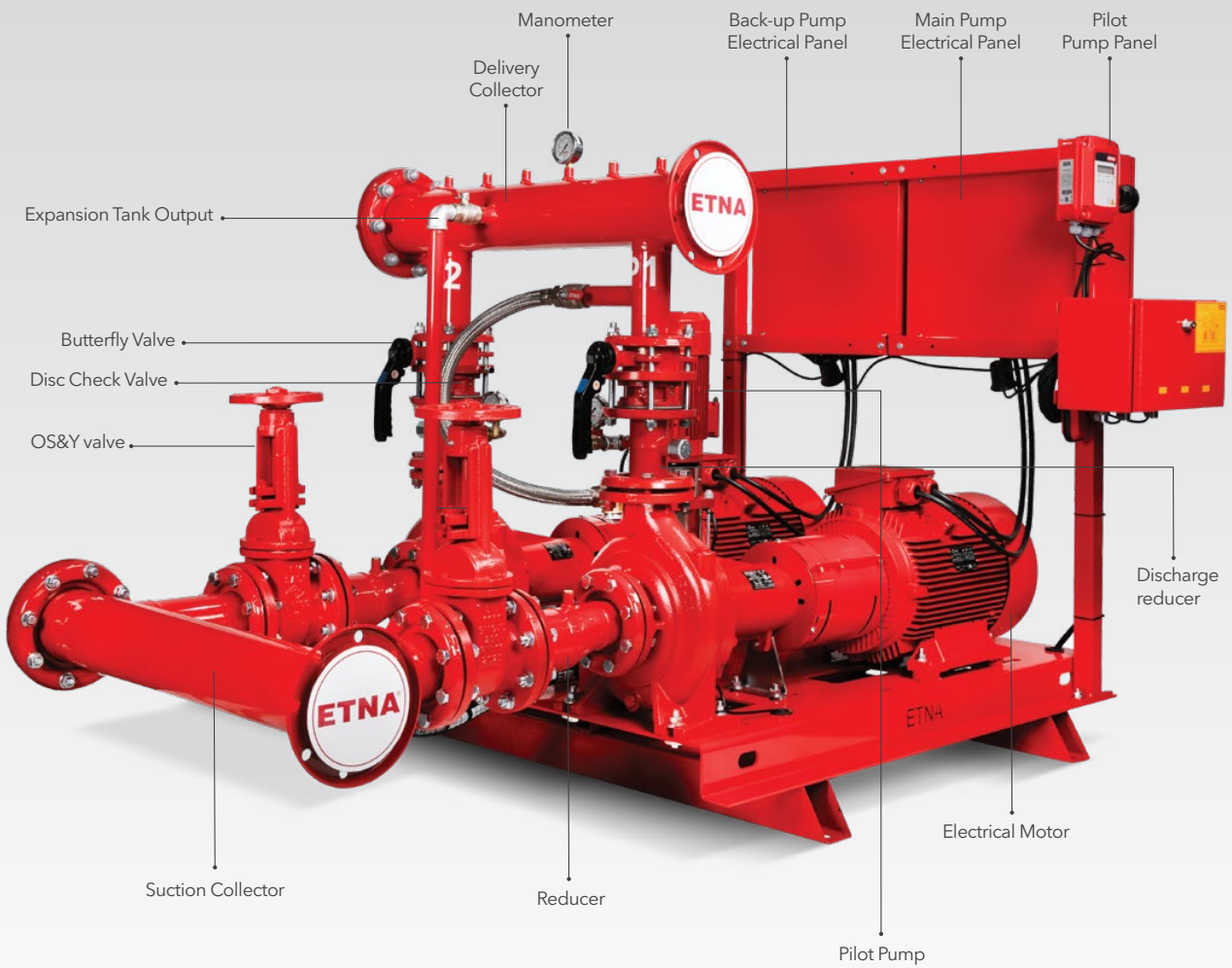

Fire Pump Control Panels in NFPA 20



Electrically Driven Pump Protection-Control Panel

- Except for the engine, all outlet connections are low voltage (12/24 Vdc)
- 3 Voltmeters
- 3 Ammeters (max.1000 A)
- Grid phase meter 50/60 Hz
- Phase sequence
- Wattmeter (Active power)
- Varmeter (Reactive power)
- V/A meter (Current power)
- Cosine meter (Power factor)
- Total operating time
- Partial operating time
- Automatic - Manual switch, manual start and stop in manual mode



Diesel Driven Pump Protection-Control Panel

- Except for the engine, all outlet connections are low voltage (12/24 Vdc)
- 2 Batteries
- 2 Voltmeters
- 2 Battery ammeters
- Tachometer
- Temperature gauge
- Oil temperature gauge
- Oil pressure gauge
- Fuel level gauge
- 2 Battery charging rectifiers
- Battery efficiency control
- Operation error report
- Manual operation buttons
- Warning lamp test button
- Test commissioning
- Monitoring individual charging of batteries
- 3+3 = 6-cycle automatic start-up attempt from batteries
- Automatic - Manual switch, manual start and stop in manual mode

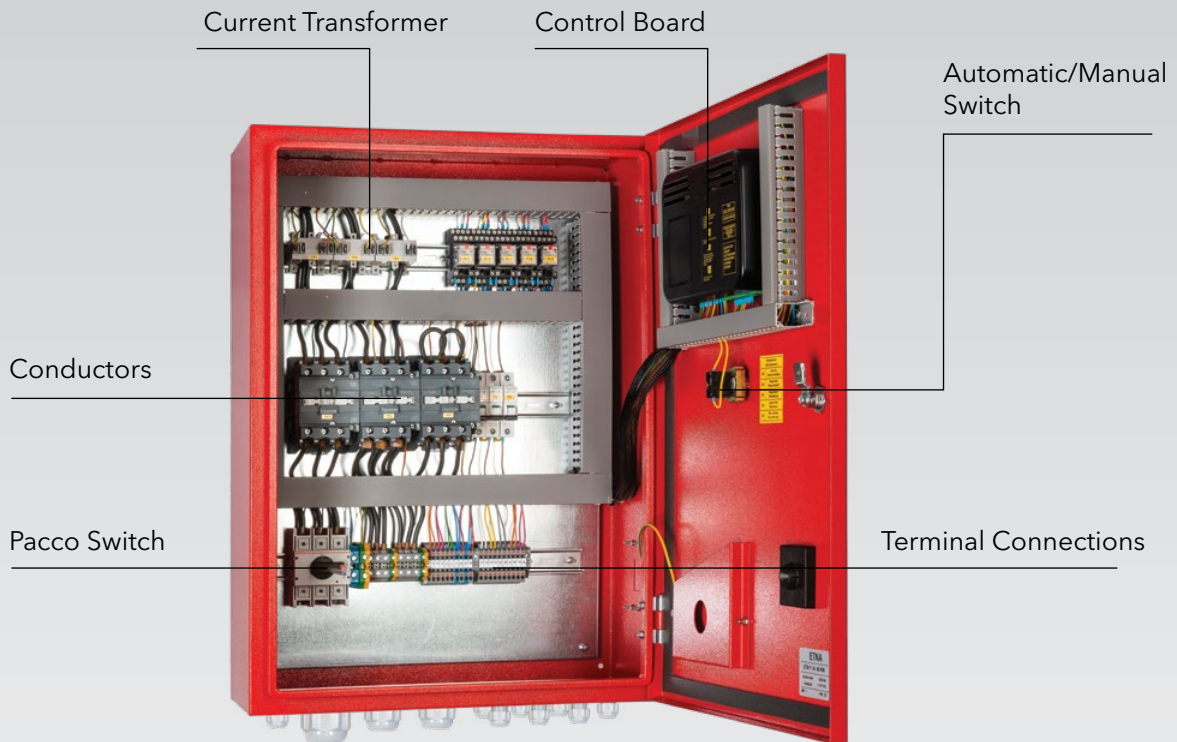

Figure 6: NFFPA 20 Electrical Fire Panel Interior

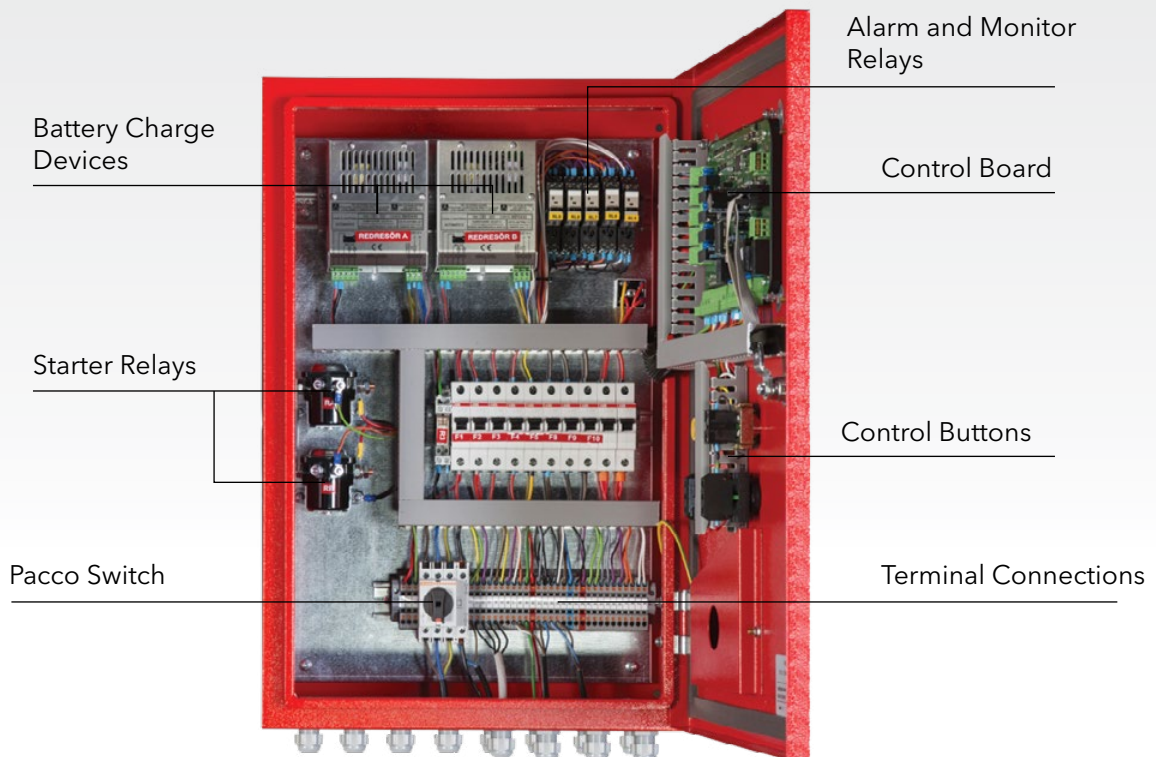

Figure 7: NFFPA 20 Diesel Fire Panel Interior



Dudullu Organize Sanayi Bölgesi 2. Cadde No: 14
34775 Ümraniye- İstanbul / Turkey
Tel : +90 216 561 47 74 (Pbx) • Fax : +90 216 561 47 50
www.etna.com.tr/en • info@etna.com.tr



ETNA®

0850 455 38 62
customer service